

REVISIONS

P	LTR	DESCRIPTION	DATE	DWN	APVD
A		INITIAL RELEASE	18DEC2014	DW	CW
B		ECR-15-013750	18SEP2015	DW	CW
B1		ECR-15-016224	05NOV2015	DW	CW
B2		ECR-16-017507	13DEC2016	QY	CW

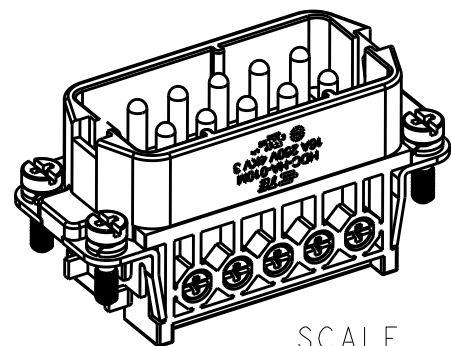

SCALE 1:1

TYPE-1, T2010102101-000, TE LOGO
 类型-1, T2010102101-000, TE LOGO

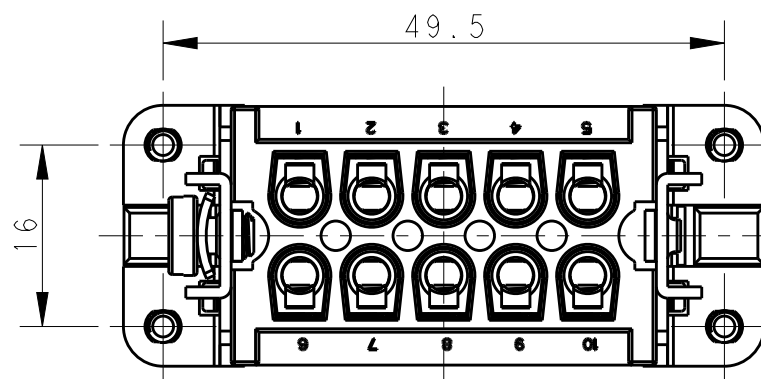

10X M3 SCREW, RECOMMENDED
 TIGHTENING TORQUE 0.5Nm
 10X M3 螺丝, 推荐锁紧力矩0.5Nm

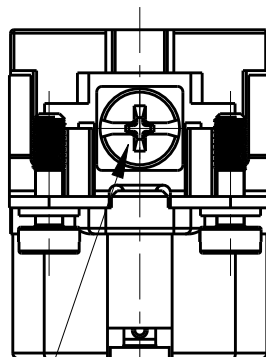

M4 SCREW RECOMMENDED
 TIGHTENING TORQUE 1.2Nm
 M4 螺丝, 推荐锁紧力矩1.2Nm

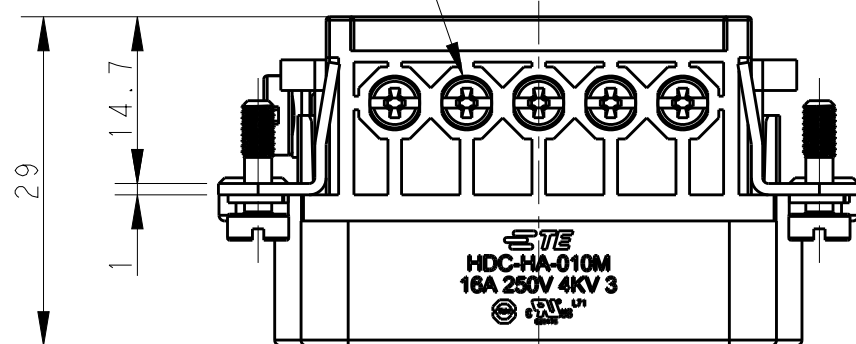

NOTES:
 1. TECHNICAL CHARACTERISTICS:
 INSULATION MATERIAL: PC
 RATED VOLTAGE: 250 V
 RATED CURRENT: 16 A
 INSULATION RESISTANCE: $\geq 400M\Omega$
 RATED IMPULSE VOLTAGE: 4 KV
 POLLUTION DEGREE: 3
 FLAMMABILITY: UL94V-0
 MATING CYCLES: 500 CYCLES
 WIRE RANGE: 0.5-2.5 mm² (20-14 AWG)
 CONTACT FINISH: SILVER PLATED
 CONTACT TYPE: SCREW CONTACT

注释:
 1. 技术参数:
 绝缘材料: PC
 额定电压: 250V
 额定电流: 16A
 绝缘电阻: $\geq 400M\Omega$
 额定脉冲电压: 4 KV
 污染等级: 3
 阻燃等级: UL94V-0
 插拔次数: 500 次
 接线范围: 0.5-2.5 mm² (20-14 AWG)
 端子表面处理: 镀银
 接线类型: 螺丝连接

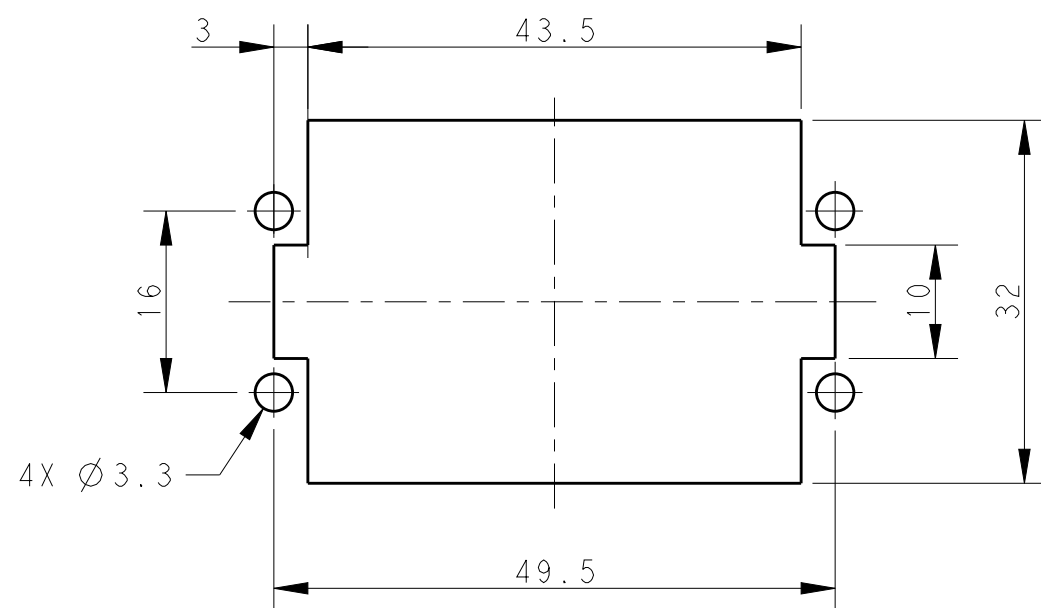

PANEL CUT FOR INSERTS FOR USING
 WITHOUT HOODS/ HOUSINGS
 不用防护外壳时芯件的安装开孔图

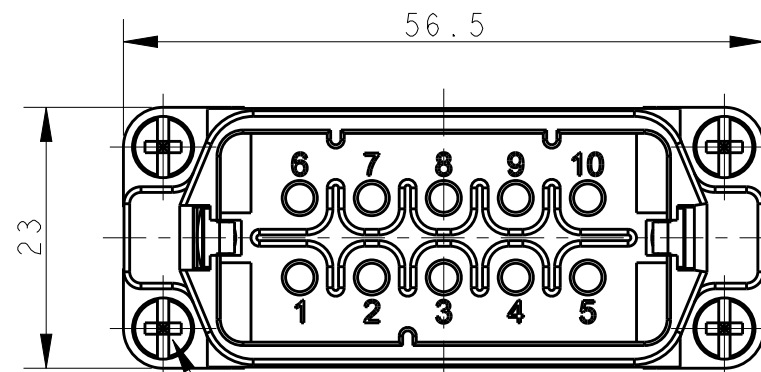

4X M3 SCREW, RECOMMENDED
 TIGHTENING TORQUE 0.5Nm
 4X M3 螺丝, 推荐锁紧力矩0.5Nm

THIS DRAWING IS A CONTROLLED DOCUMENT.		DWN 18DEC2014 DAVID WANG	TE Connectivity	
		CHK 18DEC2014 CHRIS WANG		
		APVD 18DEC2014 XU XIANG	NAME HA-010-M	
DIMENSIONS: mm		PRODUCT SPEC 108-137045	SIZE CAGE CODE DRAWING NO RESTRICTED TO	
TOLERANCES UNLESS OTHERWISE SPECIFIED: 0 PLC ±- 1 PLC ±- 2 PLC ±- 3 PLC ±- 4 PLC ±- ANGLES ±-		APPLICATION SPEC 114-137045	A300779 ©-T2010102101000	
MATERIAL		WEIGHT	SCALE 3:2 SHEET 1 OF 2 REV B2	
		Customer Drawing		

REVISIONS

P	LTR	DESCRIPTION	DATE	DWN	APVD
-		SEE SHEET 1	-	-	-

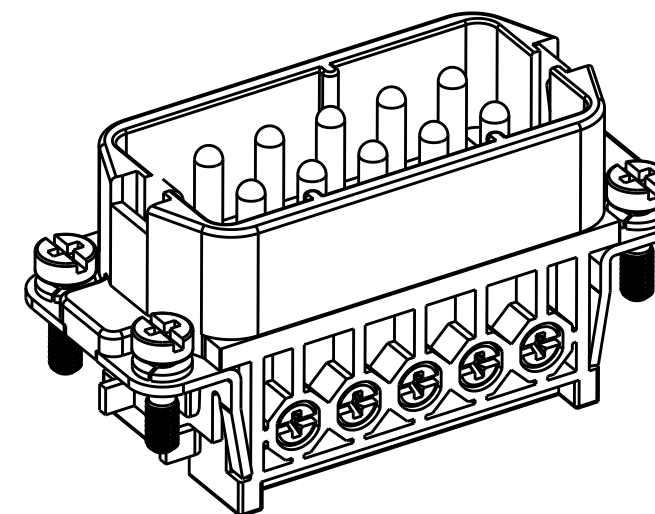
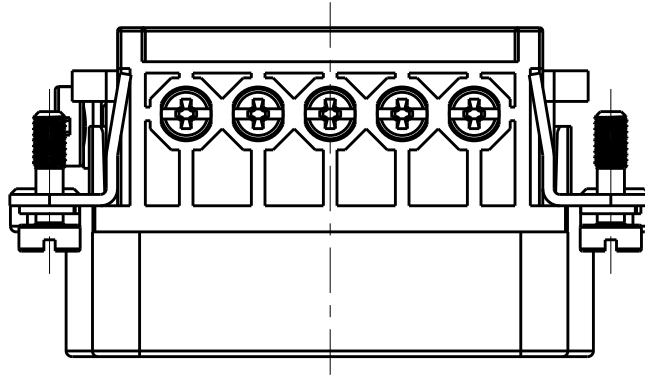
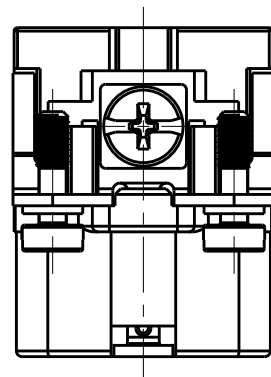
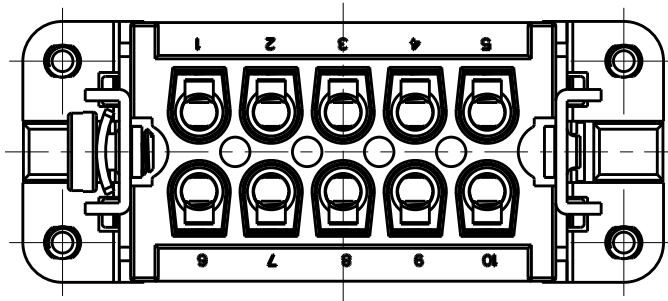

NOTE:
SEE SHEET 1
注释:
见页 1

ALL DIMENSIONS ARE SAME AS TYPE 1,
EXCEPT THOSE DEFINED IN THIS TYPE.
除了在本类型中定义的尺寸外,其它尺寸同类型 1

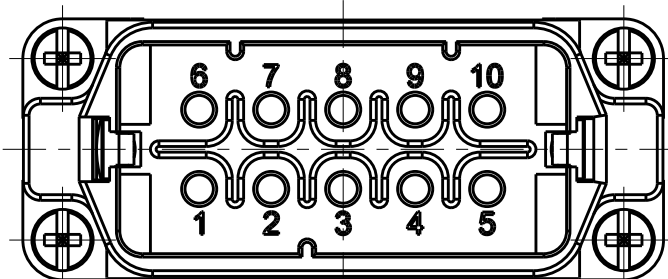

TYPE-2, T2010102101-001, NO LOGO
类型-2, T2010102101-001, 无 LOGO

T2010102101-001	HA-010-M	HA-010 MALE INSERT, NO LOGO HA-010公插, 无LOGO	TYPE-2 类型-2
T2010102101-000	HA-010-M	HA-010 MALE INSERT HA-010公插	TYPE-1 类型-1
PART NUMBER 料号	PART DESCRIPTION 描述		TYPE 类型

THIS DRAWING IS A CONTROLLED DOCUMENT.		DWN DAVID WANG 18DEC2014		
DIMENSIONS: mm		CHK CHRIS WANG 18DEC2014		
TOLERANCES UNLESS OTHERWISE SPECIFIED:		APVD XU XIANG 18DEC2014	NAME HA-010-M	
0 PLC ±-		PRODUCT SPEC 108-137045	SIZE A3	
1 PLC ±-		APPLICATION SPEC 114-137045	CAGE CODE 00779	
2 PLC ±-		WEIGHT -	DRAWING NO T2010102101000	
3 PLC ±-		Customer Drawing	RESTRICTED TO -	
4 PLC ±-			SCALE 3:2	SHEET 2 OF 2
ANGLES ±-				
FINISH -				
MATERIAL -				